

ANDELSEIERS ANSVAR

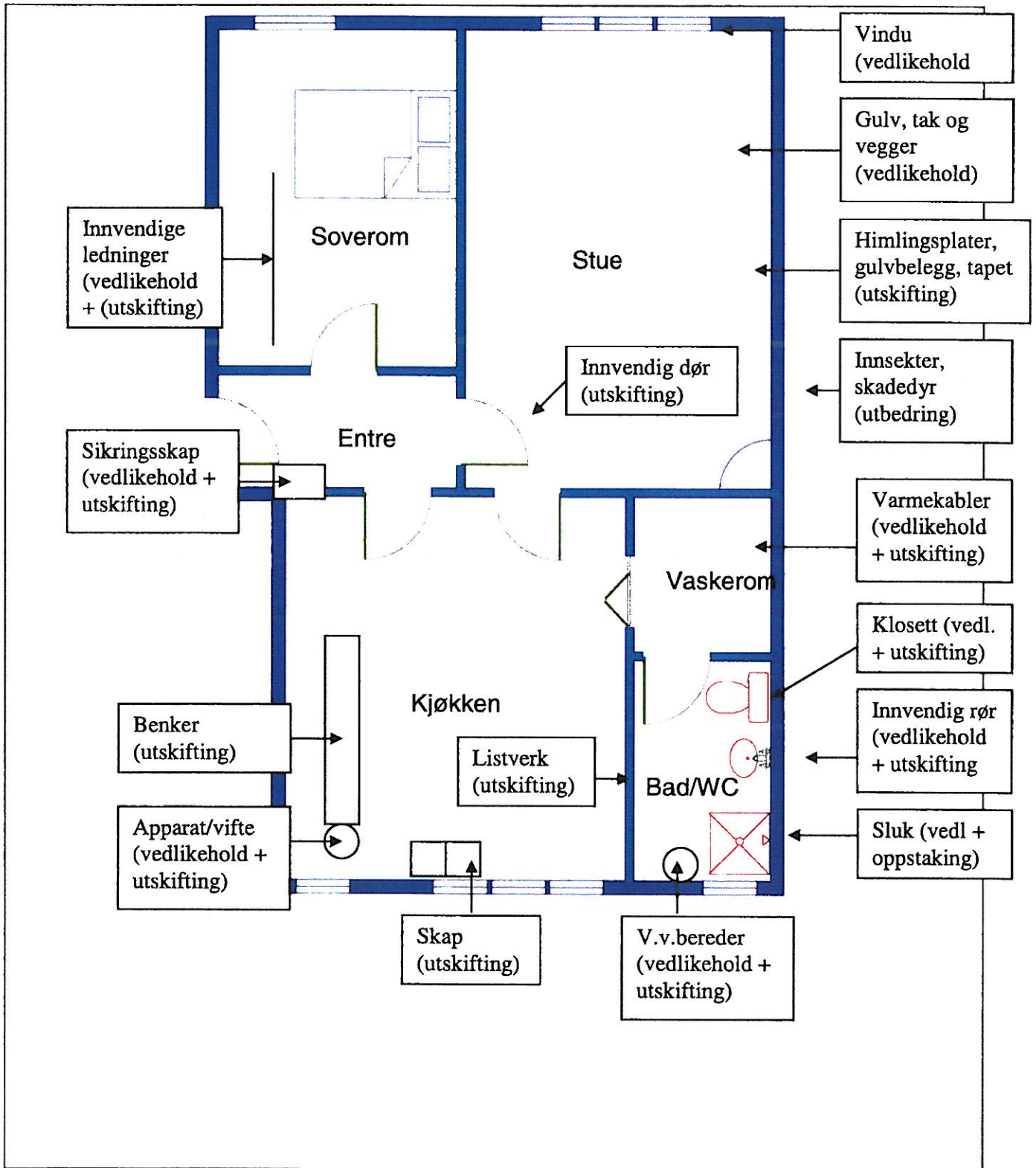

BORETTLAGETS ANSVAR

